

ET1010 User Manual

Features

- ※ Support MODBUS RTU protocol
- ※ Support cascading, non-inductive expansion of the number of IO interfaces
- ※ No configuration required, plug and play
- ※ Adaptive master-slave station, adaptive register address
- ※ Communication delay in milliseconds
- ※ No packet loss and abnormality in high-speed communication
- ※ The hardware indicator light presents the communication status in real time



Specifications

RS485	Number of ports	1way
	Operating mode	Slave
	Support baud rate	115200/9600/4800/2400
do	Number of ports	4way
	output type	Relay output
	Relay capacity	5A/30VDC 5A/250VAC
DI	Number of ports	4way
	input type	NPN/PNP/dry contact
	electrical characteristics	Optocoupler isolation
Electrical parameters	Rated voltage	DC12V, working range DC12~24V
	rated power	<1W
	power protection	Anti-static, anti-surge, anti-reverse connection
Environmental parameters	Operating temperature	-40~80°C
	storage temperature	-40~85°C
	environment humidity	10-90% RH (non-condensing)
Mechanical parameters	size	80*71*63mm
	weight	150g
	material	ABS



Interface Description

No.	Name	Meaning	No.	Name	Meaning
1	Pow	Power indicator light, always on	twenty one	Vout	The positive pole of the external power supply, the voltage is equal to the input power supply voltage
2	Work	Working indicator light, 1 second strobe	twenty two	PGND	DI signal input isolation ground
3	Net	reserve	twenty three	DI1	DI1 signal input
4	Recv	reserve	twenty four	DI2	DI2 signal input
5	Send	reserve	25	DI3	DI3 signal input
6	--	reserve	26	DI4	DI4 signal input
7	Alarm	Alarm indicator light, cascaded device communication is abnormal and always on	27	SW	Dry: Dry contact/PNP signal Wet: NPN signal
8	link	Connection indicator, cascaded device plugged in is always on	28	RST	reset button
9	DI1	DI indicator	29	DO1	Relay 1 output
10	DI2	DI indicator	30	DO1	Relay 1 output
11	DI3	DI indicator	31	DO2	Relay 2 output
12	DI4	DI indicator	32	DO2	Relay 2 output
13	DO1	DO light	33	DO3	Relay 3 output
14	DO2	DO light	34	DO3	Relay 3 output
15	DO3	DO light	35	DO4	Relay 4 output
16	DO4	DO light	36	DO4	Relay 4 output
17	Vin	Power input positive stage	37	Dial code	1-5 means the MODBUS communication address, restart to take effect
18	GND	Power input negative	38	Dial code	6-8 Set the baud rate, restart to take effect
19	485A	RS485-A	39	M	M port, for upward cascading
20	485B	RS485-B	40	S	S port, for cascading down

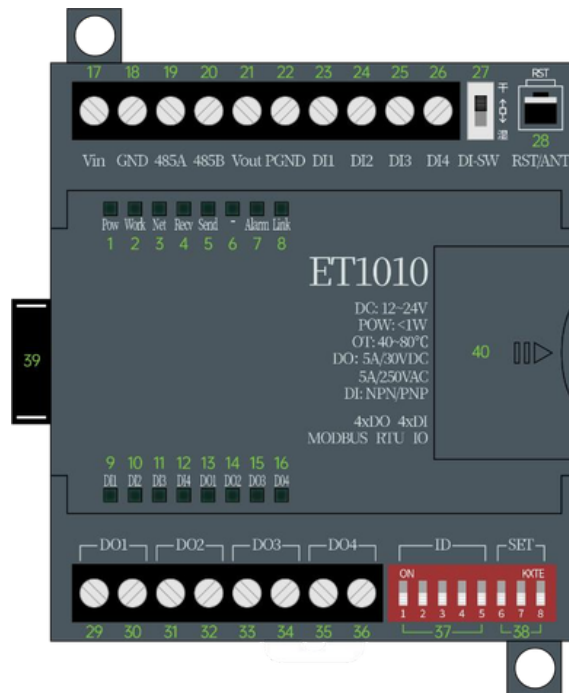

Easy to use

- ① Connect the M port of ET1010 to the S port, the first ET1010 is the master station.
- ② Dial the communication address (dial code 1-5) of each ET product to a different position to avoid communication conflicts.
- ③ Connect the power supply of the master station and the RS485 communication line, and then communicate with the master station through modbus protocol.

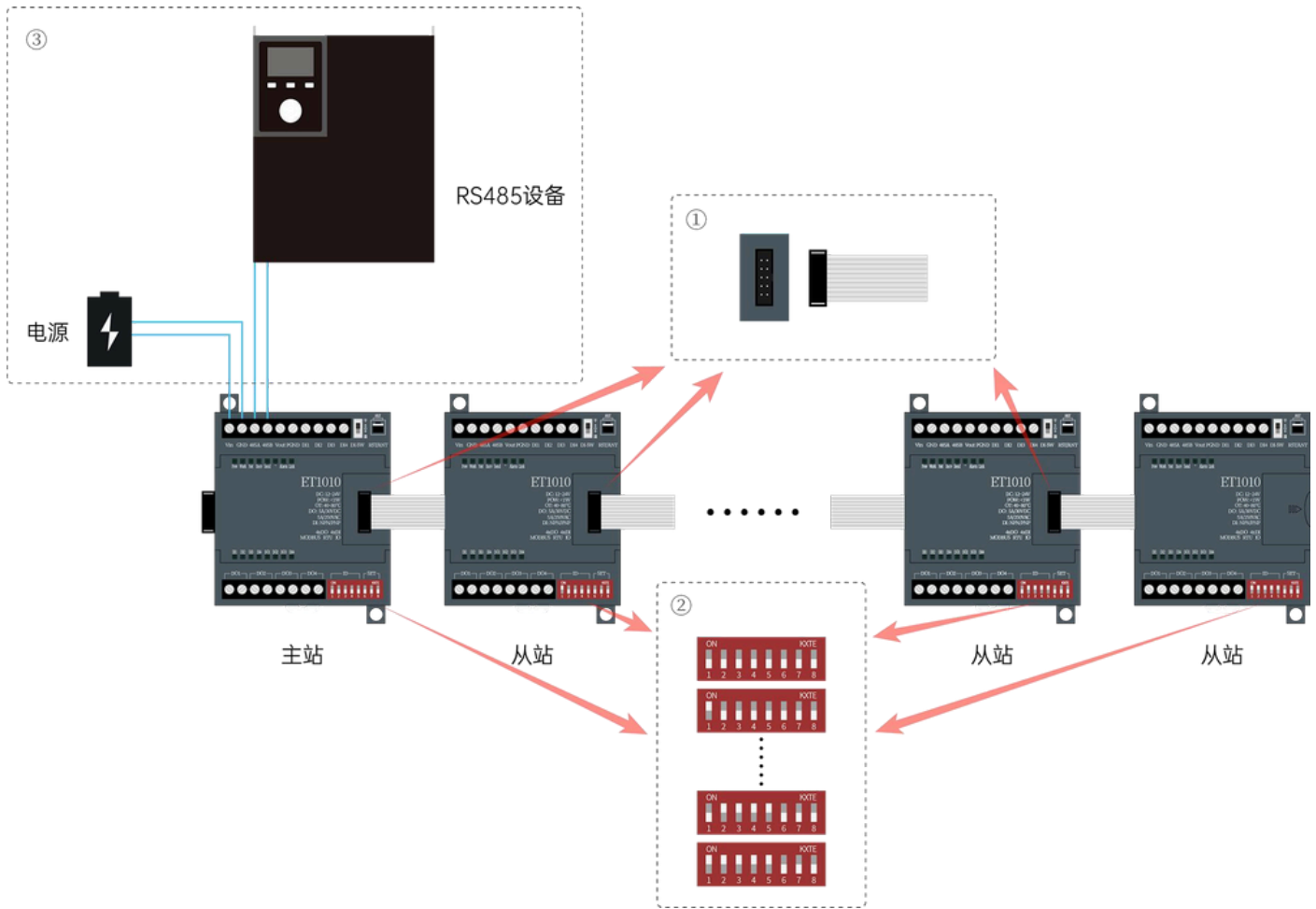

Tips:

The MODBUS communication address is the communication address of the master station.

The register addresses start from 0000H and are arranged sequentially according to the cascade sequence.

Register Address Table

Register type	Register address	Register properties	Support function code	Note
DO register	0000H~0003H	DO1-DO4	01 (read) 05 (write a single) 0F (write multiple)	The first ET1010 module
	0004H~0007H	DO5-DO8		Second ET1010 module
	0008H~000BH	DO9-DO12		The third ET1010 module
	000CH~000FH	DO13-DO16		Fourth ET1010 module

DI register	0000H~0003H	DI1-DI4	02 (read)	The first ET1010 module
	0004H~0007H	DI5-DI8		Second ET1010 module
	0008H~000BH	DI9-DI12		The third ET1010 module
	000CH~000FH	DI13-DI16		Fourth ET1010 module

holding register	1000H	version + address	03 (read)	
	1001H	DI quantity + DO quantity		
	1002H	AI quantity + AO quantity		reserve

Frequently asked questions

- ① **Q: Why is the DI data collection normal, but the control DO is wrong?**
 A: Please check the address code of the cascade module, it cannot be consistent. The address code does not affect data collection, but it will affect downlink control.
- ② **Q: Why is there an error when reading 16 DIs after connecting 4 ET1010 modules?**
 A: Please read the 1000H-1002H register data first to determine how many slave IOs the master module has detected. If it does not match the actual situation, you can find the problematic module according to the Alarm light. The Alarm light is always on, indicating that the communication of the lower-level module is abnormal.
- ③ **Q: I have 8 modules. If there is a communication problem with one module in the middle, will the subsequent modules be unable to communicate?**
 A: Yes, the cascading of the modules is similar to the high-speed rail carriages, which are disconnected in the middle, and the high-speed rail head will only pull the remaining carriages forward. The adaptive algorithm of the main module can ensure timely detection of abnormalities: when requesting IO of abnormal modules, an error will be replied, and the remaining modules will work stably.
- ④ **Q: I have 4 modules that are already working normally, and want to add 2 more, how do I do it?**
 A: Direct cascading, only need to ensure that the address code is inconsistent, the main module can be self-adaptive.
- ⑤ **Q: How many modules can be cascaded at most?**
 A: The default firmware supports a maximum of 10, if you have special needs, feel free to harass customer service.
- ⑥ **Q: Is it considered to introduce modules of other interface types, and the protocols are compatible with each other?**
 A: Look forward to it, the answer is yes.

DIP Switch Description

ID	二进制	图示	ID	二进制	图示
0	00000		16	10000	
1	00001		17	10001	
2	00010		18	10010	
3	00011		19	10011	
4	00100		20	10100	
5	00101		21	10101	
6	00110		22	10110	
7	00111		23	10111	
8	01000		24	11000	
9	01001		25	11001	
10	01010		26	11010	
11	01011		27	11011	
12	01100		28	11100	
13	01101		29	11101	
14	01110		30	11110	
15	01111		31	11111	

1-5 Set MODBUS Communication Address

SET	二进制	图示	波特率	ID	二进制	图示	波特率
0	000		9600	4	100		115200
1	001		预留	5	101		预留
2	010		4800	6	110		预留
3	011		预留	7	111		预留

6-8 Set Baud Rate

Wiring Instructions

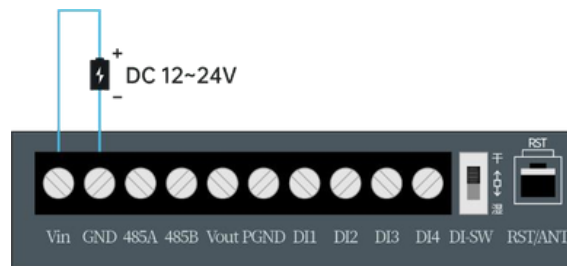

Power Wiring Diagram

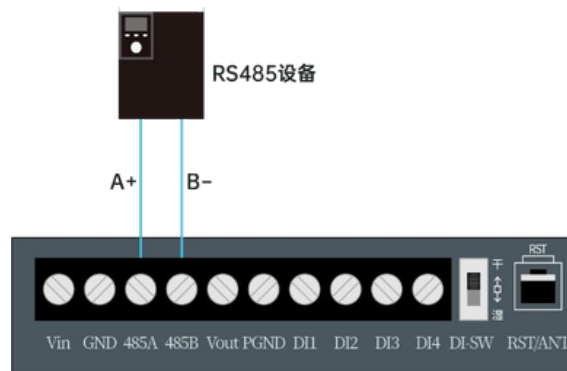

RS485 wiring diagram

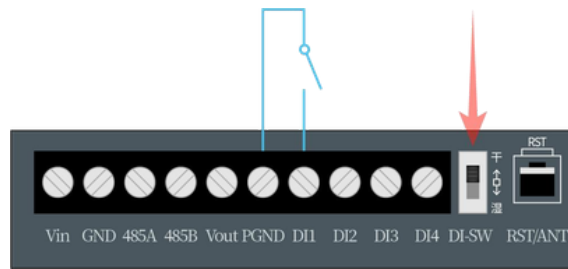

DI(Dry contact) wiring diagram

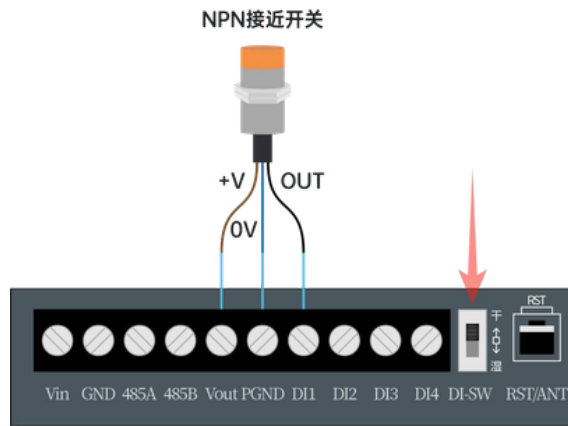

DI(NPN) wiring diagram

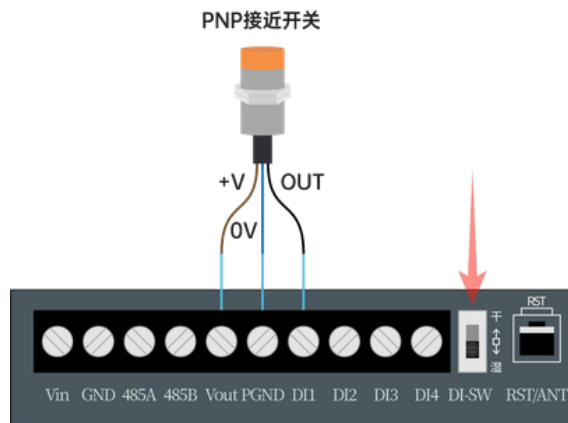

D.I(PNP) wiring diagram

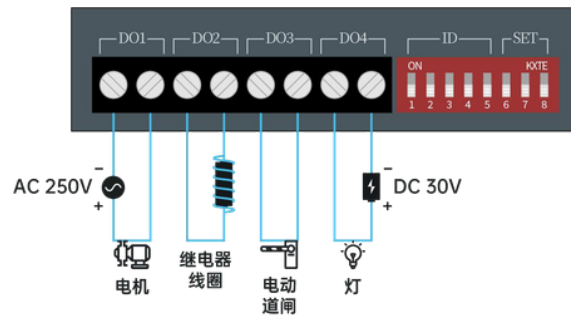

DO Wiring Diagram