

ET3420 Datasheet

Features

- ※ Support LTE 4G
- ※ Support cascade, expand the number of IO interfaces without induction
- ※ No configuration required, plug and play
- ※ Communication delay in milliseconds
- ※ No packet loss and no abnormality in high-speed communication



Specifications

LTE	LTE-FDD	Band1/Band3/Band5/Band8
	LTE-TDD	Band34/Band38/Band39/Band40/Band41
RS485	Number of interfaces	1way
	Working mode	Master
	Baud Rate	115200/9600/4800/2400
AO	Number of interfaces	4-way
	Output type	4-20mA
	Accuracy	12-bit
AI	Number of interfaces	4-way
	Type	4-20mA
	Accuracy	12-bit
Electrical parameters	Rated voltage	DC12V, working range DC12~24V
	Rated power	<5W
	Power protection	Anti-static, anti-surge, anti-reverse connection
Environmental parameters	Operating temperature	-40~80 °C
	Storage temperature	-40~85 °C
	Ambient humidity	10-90% RH (non-condensing)
Mechanical parameters	Size	80*71*63mm
	Weight	150g
	Material	ABS

Description

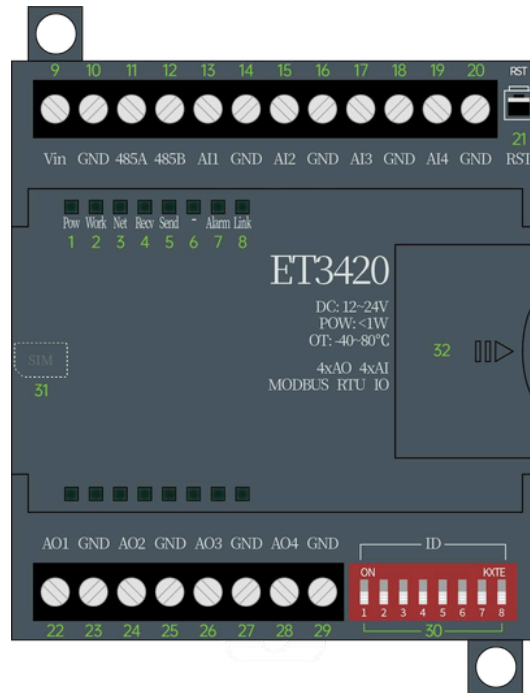

NO	Name	Meaning	NO	Name	Meaning
1	Pow	Powerindicator,always on	17	Vout	AI3 signal input
2	Work	Card not found: Flashes slowly Cardfound:Flash PDP Registration Successful: Strobe	18	GND	AI signal input ground
3	Net	TheSOCKETconnectionisalwayson	19	AI4	AI4 signal input
4	Recv	Networkdatareceptionlight	20	GND	AI signal input ground
5	Send	Networkdatasendinglight	21	RST	Reset button
6	--	obligate	22	AO1	AO1 signal output
7	Alarm	Aalarmindicatorandcommunicationexceptionlight always on	23	GND	AO signal output place
8	Link	Connectionlight,always onaftercascadingdeviceplugged	24	AO2	AO2 signal output
9	Vin	Powerinputispositive	25	GND	AO signal output place
10	GND	Powerinputisnegative	26	AO3	AO3 signal output
11	485A	RS485-A	27	GND	AO signal output place
12	485B	RS485-B	28	AO4	AO4 signal output
13	AI1	AI1signalinput	29	GND	AO signal output place
14	GND	Alsinalinputground	30	DIP	1-8 indicates the MODBUS communication address (0-255), take effect after restart
1	AI2	AI2signalinput	31	SIM	External SIM card slot
5	GND	Alsinalinputground	32	S	S-mount for downward cascade

1

6

Easy To Use

- ① ET3420 can be cascaded with ET1010/ET1020 modules at will, and take ET3420 as the main station.
- ② Dial the DIP switch for each ET product to a different position (set the communication address) to avoid communication conflicts.
- ③ Configure the server address of the ET3420 to communicate with the ET3420 via MODBUS/JSON protocol.

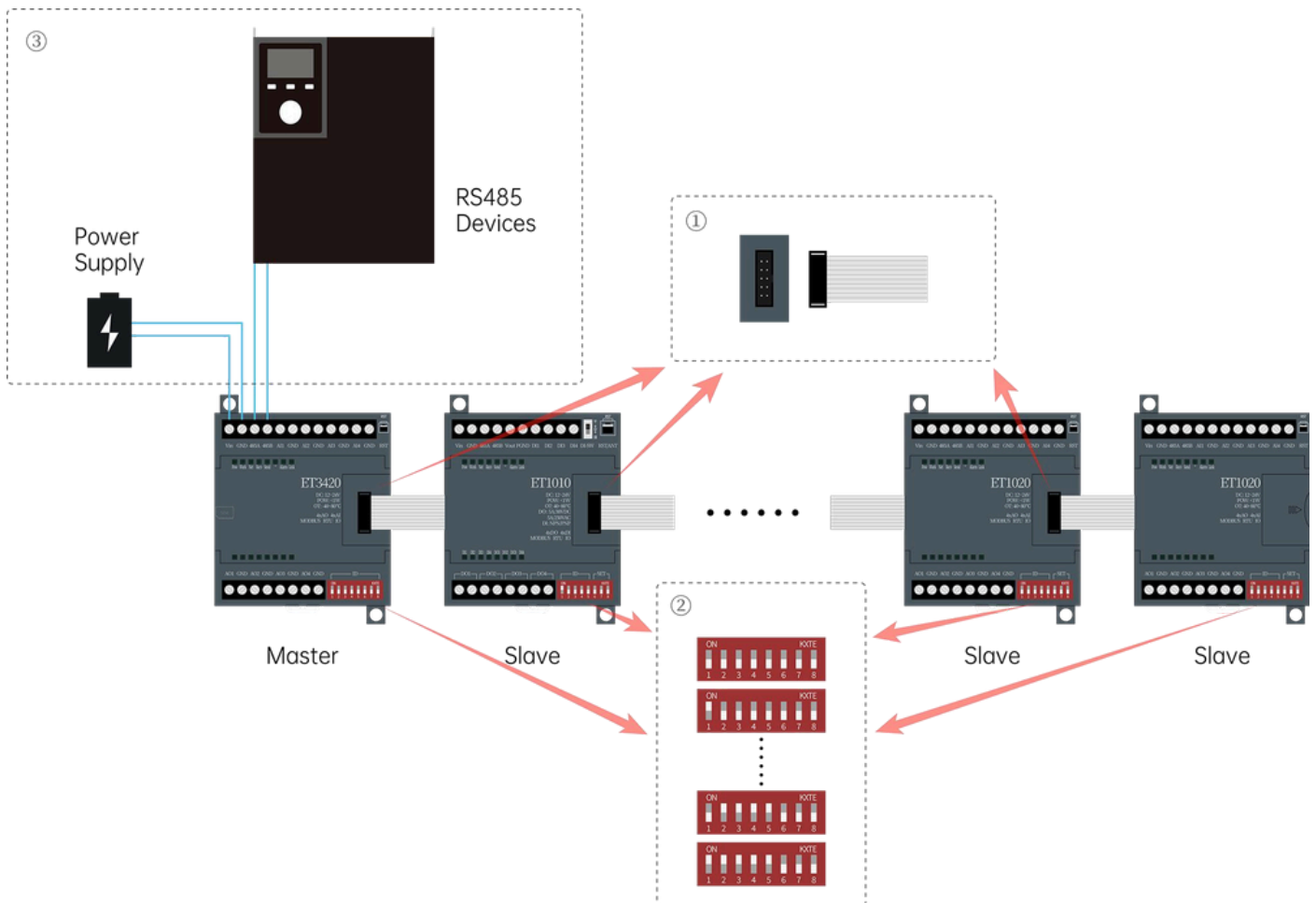

Tips:
 The MODBUS communication address is the communication address of the main station.
 The register addresses are arranged sequentially from 0000H in cascading order.



Register Address Table

Register type	Register address	Register properties	Feature codes are supported	Note
DO register	0000H~ 0003H	DO1-DO4	01 (Read) 05 (Write register) 0F (Write multiple registers)	The first ET1010 module
	0004H~ 0007H	DO5- DO8		The second ET1010 module
	0008H~000BH	DO9-DO12		The third ET1010 module
	000CH~000FH	DO13-DO16		The fourth ET1010 module

DI registers	0000H~ 0003H	DI1 -DI 4	02 (Read)	The first ET1010 module
	0004H~ 0007H	DI5 -DI 8		The second ET1010 module
	0008H~000BH	DI9- DI 12		The third ET1010 module
	000CH~000FH	DI13 -DI 16		The fourth ET1010 module

AO registers	0000H~ 0003H	DO1-DO4	03 (Read) 06 (Write register) 10 (Write multiple register) Unit uA	The first ET1020 module
	0004H~ 0007H	DO5- DO8		The second ET1020 module
	0008H~000BH	DO9-DO12		The third ET1020 module
	000CH~000FH	DO13-DO16		The fourth ET1020 module

AI registers	0000H~ 0003H	DI1 -DI 4	04 (read) Unit uA	The first ET1020 module
	0004H~ 0007H	DI5 -DI 8		The second ET1020 module
	0008H~000BH	DI9- DI 12		The third ET1020 module
	000CH~000FH	DI13 -DI 16		The fourth ET1020 module

Hold registers	1000H	Version + address	03 (read)	
	1001H	Number of DI + Number of DO		
	1002H	Number of AI + Number of AO		

FAQ

① Q: Why is the AI data collection normal, but the control AO is incorrect?

A: Please check the address code of the cascade module, it cannot be consistent. The address code does not affect data collection, but it does affect downstream control.

② Q: Why does an ET3420 module cascade 3 ET1020 and read 16 DI channels with an error?

A: Please read the 1000H-1002H register data first to determine how many slave IO are detected by the master module. If it does not match the actual situation, you can find the problematic module based on the alarm lamp, and the alarm lamp is always on, indicating that the communication of the subordinate module is abnormal.

③ Q: I have 8 modules, if there is a communication problem with the middle module, will the subsequent modules fail to communicate?

A: Yes, the cascade of modules is similar to a high-speed rail car, the middle is disconnected, and the high-speed rail head will only pull the remaining carriages forward. The adaptive algorithm of the main module can ensure that anomalies are detected in time: errors will be replied when abnormal module IO are requested, and the remaining modules will work stably.

Q: I have 4 modules that are already working normally, and I want to add 2 more, how can I do this?

④

A: Directly connected, only need to ensure that the address code is inconsistent, and the main module can be adaptive.

⑤ Q: How many modules can be cascaded?

A: The default firmware supports up to 10, if you have special needs, please feel free to harass customer service.

Q: Are you considering launching modules with other interface types and adapting protocols to each other?

⑥

A: yes, developing.

DIP switch description

ID	Binary	hexadecimal	Icon	ID	Binary	hexadecimal	Icon
0	00000000	0x00		16	00010000	0x10	
1	00000001	0x01		17	00010001	0x11	
2	00000010	0x02		18	00010010	0x12	
3	00000011	0x03		19	00010011	0x13	
4	00000100	0x04		20	00010100	0x14	
5	00000101	0x05		21	00010101	0x15	
6	00000110	0x06		22	00010110	0x16	
7	00000111	0x07		23	00010111	0x17	
8	00001000	0x08		24	00011000	0x18	
9	00001001	0x09		25	00011001	0x19	
10	00001010	0x0A		26	00011010	0x1A	
11	00001011	0x0B		27	00011011	0x1B	
12	00001100	0x0C		28	00011100	0x1C	
13	00001101	0x0D		29	00011101	0x1D	
14	00001110	0x0E		30	00011110	0x1E	
15	00001111	0x0F		31	00011111	0x1F	

1-8 Set the MODBUS communication address

(Only the first 32 addresses are listed in the preceding table, and subsequent addresses can be set according to the rules in this table.)

Wiring Instructions

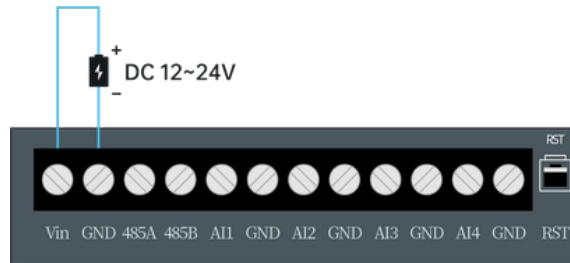
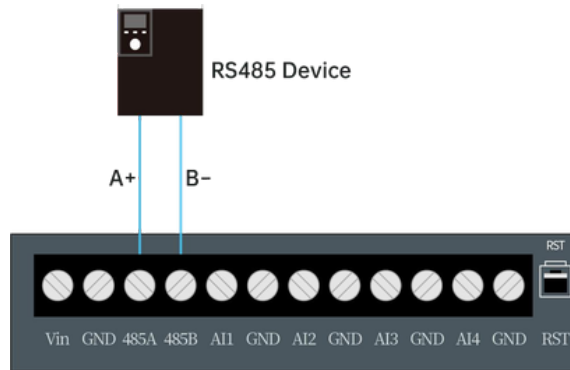
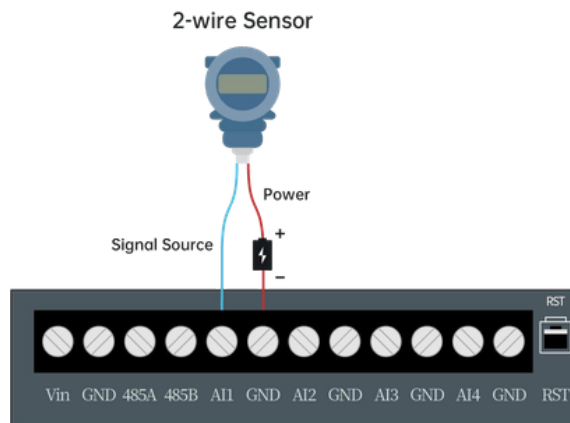

Diagram of power wiring



RS485 wiring diagram



AI wiring diagram (2-wire sensor)

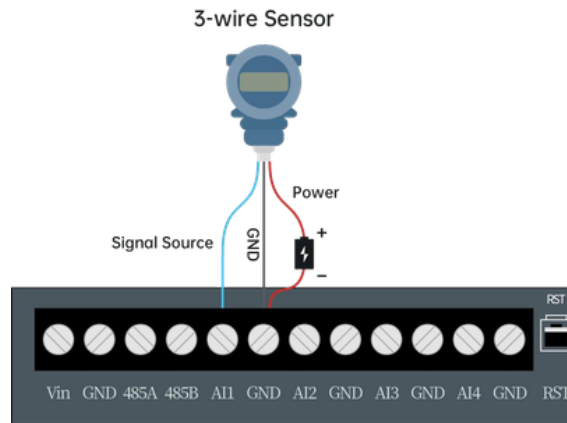

AI wiring diagram (three-wire sensor)

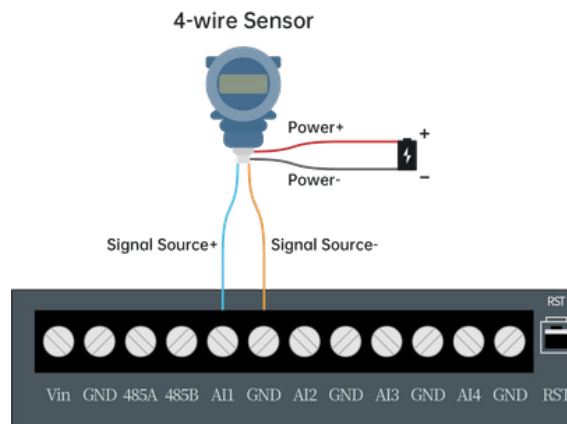

AI wiring diagram (four-wire sensor)

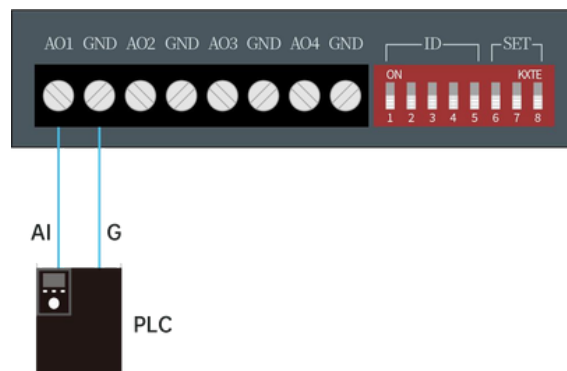

AO wiring diagram